

TECHNICAL SPECIFICATIONS AND INSTALLING DETAILS FOR STAINLESS STEEL FRICTION STAY HINGES

Following of elaborate works and longterm R&D activities, we are proud to release our enhanced stainless steel friction stay hinges. **SKB** is the first and only company to provide Turkish "TSE" and German quality certifications for manufacturing stainless steel friction stay hinges for facade windows in Turkey.

Our **SKB 610** friction stay hinges are produced in compliance with ISO 9001 standards. Sash bearing arm's width is 19 mm and the thickness is 3mm. Track thickness is 1,20mm. SKB Friction Stay Hinges are produced with 304 grade stainless steel materials. TSE standard number is: TS EN 13126-6. All other standard numbers are irrelevant to stainless steel friction stay hinges.

TECHNICAL SPECIFICATIONS

SKB Stainless Steel Friction Hinges offer durable and robust hidden sash hinges for top hung window opening functions on glass facades. This product range consists of friction stays with three different dimensions to meet various requirements of the market. Friction stays are mounted and operated on both sides of the sashes, thus eliminates left and right hinge necessity with practical installation. Products are sold in 12 sets per packages.

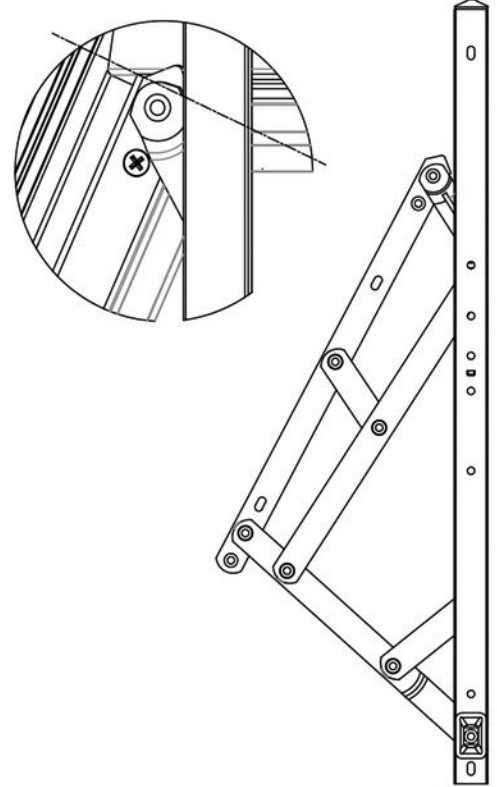

MAXIMUM SASH DIMENSIONS

CODE:	HEIGHT mm	WEIGHT kg	OPENING DEGREE 1	OPENING DEGREE 2
SKB 410	1200	90	25 ± 2°	15 ± 2°
SKB 510	1600	110	25 ± 2°	15 ± 2°
SKB 610	2000	130	25 ± 2°	15 ± 2°

SKB 410 (16")

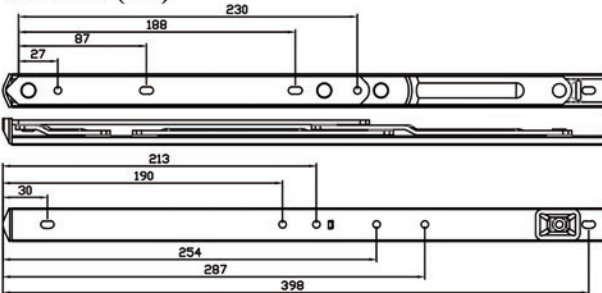

SKB 510 (20")

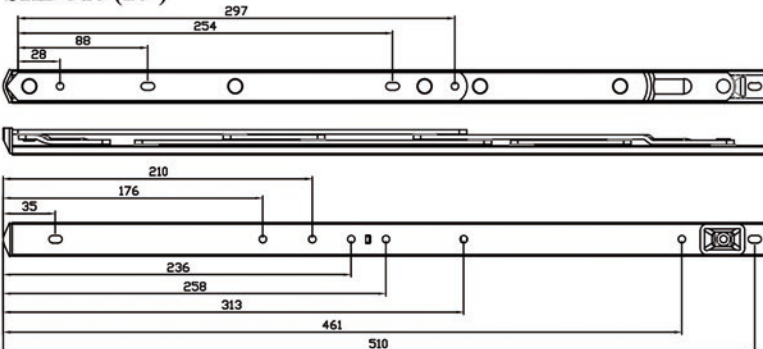

SKB 610 (24")

